

PROPERTY PLAT

Acquired from CATHERINE H. KEALY

Married or Single? _____ (Give full name of spouse)

Area by Deed _____ Acres.

Area by 0.052± Acres. Total Consideration \$ _____

Borrow Area _____ Acres. Contract Date _____, 20 _____

LOCATION

From CL Station 64+00 to CL Station 66+38.27

Section 14, Township 78 North, Range 2 East

Township (Civil) BLUE GRASS Iowa.

Sta. 66+38.27

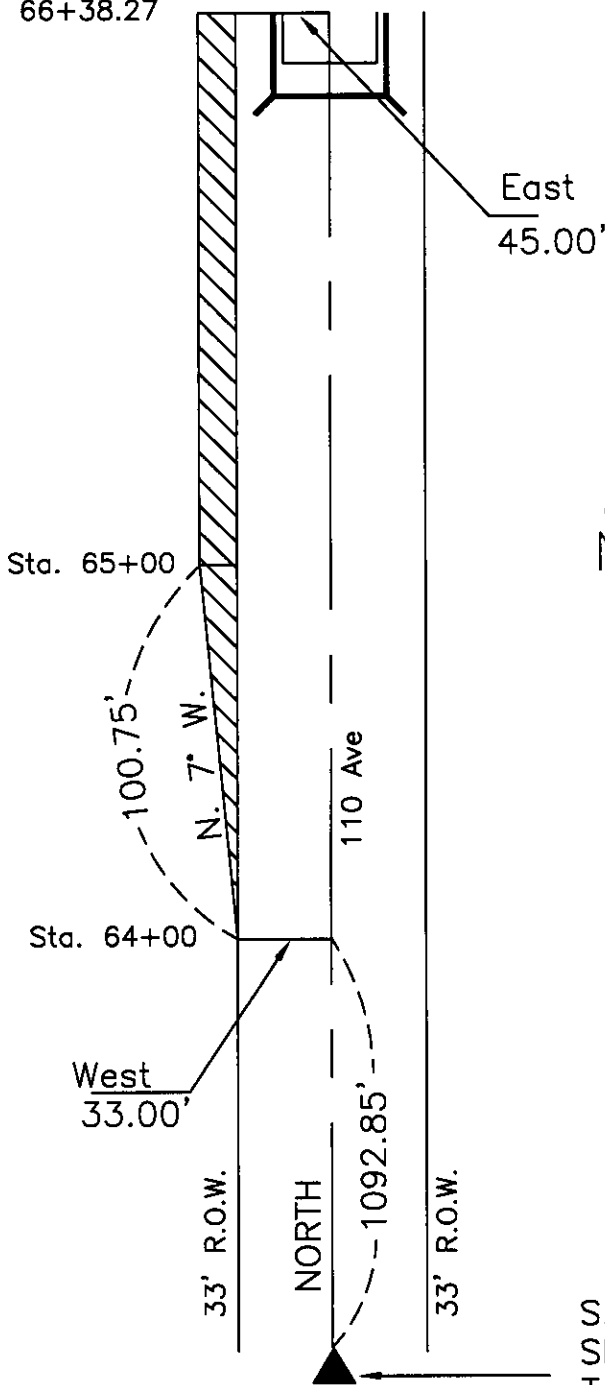

S.W. 1/4 COR
SECTION 13
T-78N, R-2E, 5.P.M.
STA. 53+07.15

Scott Project No. L-402(1)--73-82
(County)

List areas by 40 acre tracts or Gov't lots, etc. (to tenths of an acre). _____